

**WEEK TWO - SENIOR TWO PHYSICS EXERCISE SOLUTIONS.**

**(30 marks)**

1. When a car is suddenly brought to rest, a passenger jerks forward because of

- A. inertia.
- B. friction.
- C. gravity.
- D. momentum.

2. The mode of transfer of heat between the boiler and the storage tank of a hot water supply system is

- A. radiation.
- B. conduction
- C. convention
- D. evaporation.

3. A rectangular block of tin is 0.5 m long and 0.01 m thick. Find the width of the block if its mass and density are 0.45 kg and  $9000 \text{ kg m}^{-3}$  respectively.

- A.  $0.005 \times 0.45 \times 9000 \text{ m}$
- B.  $\frac{0.45}{9000 \times 0.005} \text{ m}$
- C.  $\frac{0.005}{0.45 \times 9000} \text{ m}$
- D.  $\frac{0.45 \times 0.005}{9000} \text{ m}$

4. The width of a metre rule is accurately measured by a

- A. micrometer screw gauge.
- B. vernier calliper.
- C. tape measure
- D. metre rule.

5. Which one of the following statements is true when a stone of mass 2 kg and that of 1 kg are released from the same point at the same time?’

- A. Both masses will hit the ground at the same time.
- B. The 2 kg mass will hit the ground first.
- C. The 1 kg mass will hit the ground first
- D. They fall with different speeds.

6. Force is given by the product of

- A. displacement and velocity.
- B. displacement and mass.
- C. acceleration and mass.
- D. velocity and mass.

7. When a crystal of potassium permanganate is carefully placed at the bottom of a beaker containing water it spreads uniformly in the water after some days due to

- A. diffusion
- B. capillarity
- C. surface tension
- D. Brownian motion.

8. Soap is used to wash clothes because it

- A. increases capillarity in the clothes
- B. reduces capillarity in the clothes
- C. increases surface tension allowing water to penetrate the dirt easily.
- D. reduces surface tension allowing water to penetrate the dirt easily.

9.

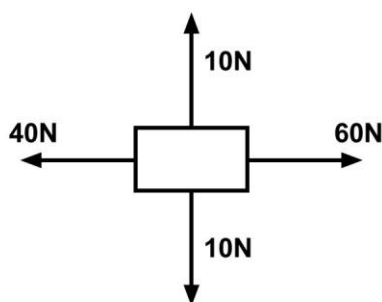

Fig. 6

Forces of 60N, 10N, 40N and 10N act on a body as shown in Fig 6.

In which direction does the body move?

- A. up wards
- B. downwards
- C. to the left
- D. to the right.

10. A mass of 0.2 kg produces an extension of 8 cm in a spring. The force required to produce an extension of 6 cm is

- A. 0.75N.
- B. 1.50N.
- C. 2.70N
- D. 24.00N.

11. (i) What is meant by **mass** of a body? (01 mark)

(ii) What happens to the weight of the body at a much higher altitude? (01 mark)

12. (a) State **Hooke's law of elasticity**. (01 mark)

(b) Different loads,  $w$ , are applied to the end of an elastic wire and the corresponding extension,  $e$ , of the wire recorded.

- (i) Sketch a labelled graph of  $e$  against  $w$ . (03 marks)

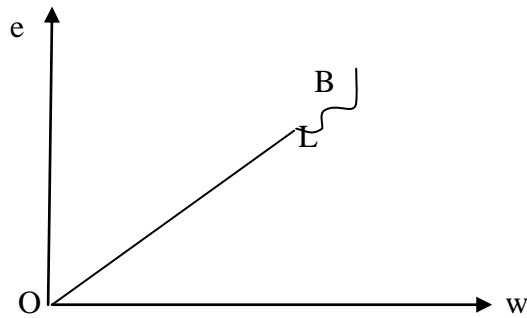

- (ii) Describe briefly the features of the graph in (b) (i). (02 marks)

- (c) A spring of natural length  $5.0 \times 10^{-2}$  m extends by  $2.0 \times 10^{-3}$  m when a force of 1.8 N acts on it.

Calculate the extension when a force of 10N is applied to the spring.

(06marks)

- (d) Describe an experiment to demonstrate the existence of surface tension (2marks)

13. (a) Distinguish between **cohesion** and **adhesion**. (02 marks)

- (b) Sketch diagrams to show the level of liquid in a capillary tube that is immersed in a liquid which has greater:

(e) adhesion than cohesion (01 mark)

(f) cohesion than adhesion (01 mark)